

Twin-screw feeder.

MWSQ

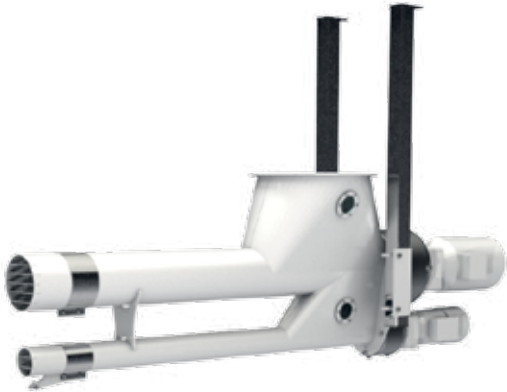

High product throughput. Accurate feeding.



Twin-screw feeder
suspended from ceiling.



Twin-screw feeder
supported on floor.

Application

The MWSQ twin-screw supplies feeds powdered products to bagging scales. Its mode of feed is divided into fast and dribble flow, resulting in both a high product throughput and an accurate desired weight.

Design

The inlet geometry ensures uniform product feed. Horizontal louvers incorporated in the outlet and a quick-action three-phase brake for controlling the dribble flow enable neat cut-off of the product flow. Frequency-controlled fast flow allows the selection of the right throughput and quantity for a wide variety of products and bag weights.

Features

- Accurate feed rate
- Wide throughput range
- High sanitation
- High operating reliability
- Easy operation and maintenance

Consistent product feeding.
Exact weights.

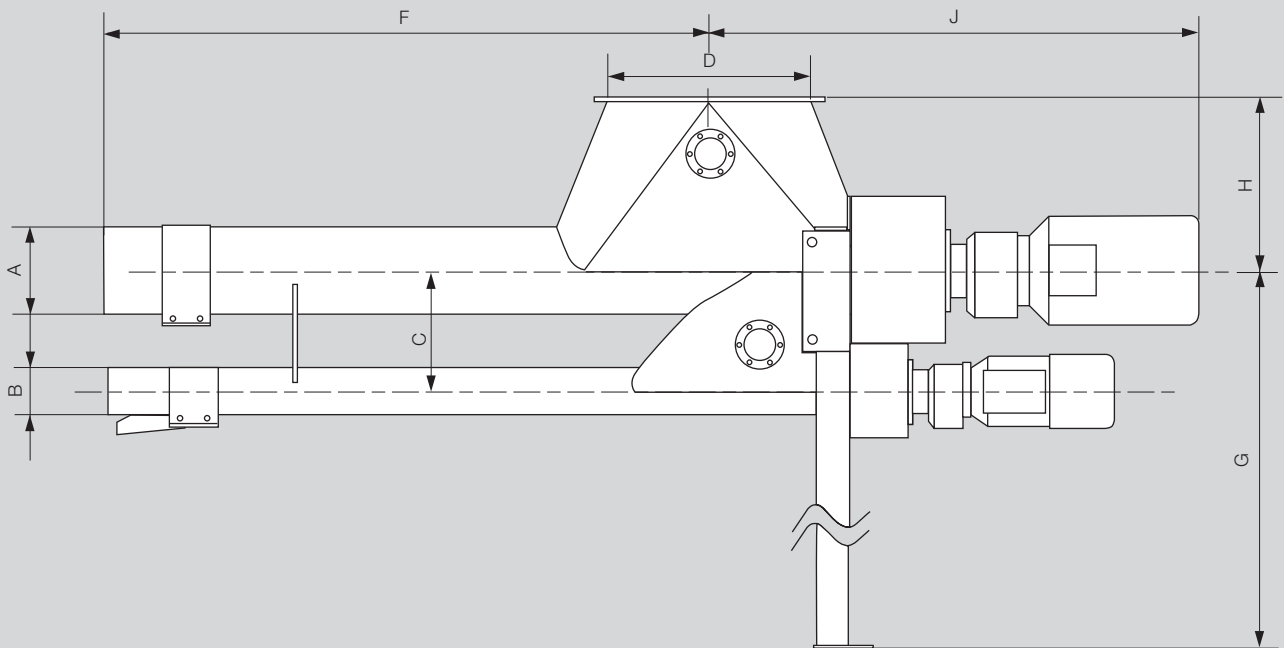

Dimensions in mm

Model	Ø A	Ø B	C	Ø D	F	J	H	G
MWSQ-1500	200	100	300	500	1500	1211	428	adjustable 420... 1720
MWSQ-1900					1900			
MWSQ-2400					2400			

Bühler AG
CH-9240 Uzwil, Switzerland
P +41 71 955 11 11
F +41 71 955 66 11
www.buhlergroup.com

