



Efficient sifting of hop powder.

### **Reliable at even the lowest temperatures.**

The MKZH vibro sieving machine is ideal for the hop processing industry by efficiently sifting hop powder at temperatures as low as minus 40° Celsius. The housing and parts that come into contact with the product are made from stainless steel and meet the strictest hygiene criteria.

The vibro sieving machine's fast-rotating beater works efficiently. The work intensity can be adjusted by adapting the beater performance for outputs of up to 500 kg/h.

### **Maximum hygiene.**

The robust housing of the vibro sieving machine MKZH and the parts that come into contact with the product are made from stainless steel meet the strictest hygiene criteria.

### **Reliable system.**

The vibration ensures that the housing, with excentric bearings accommodating the sifting basket, holds the sieve mesh open, avoiding the accumulation of product. A balanced system ensures no additional floor-impacting forces are generated.

### **Easy machinery access.**

The robust vibro sieving machine MKZH features a low-maintenance V-belt drive with V-belt tensioning device. The V-belt can be replaced very quickly as a result of the two-part cover and wide motor plate.

### **Benefits.**

Stainless steel version for **maximum hygiene**

**Reliable system** without product accumulation

**Easy machinery access**

**Fast cleaning** and maintenance

# Robust and low maintenance. Easy access to machine.



## Fast cleaning and maintenance.

The wide side openings provide sufficient space between the sifting basket and the housing, allowing simple and fast cleaning. The removable door hinges allow for quick sieve checks and changes to be carried out without having to dismantle the machine. The sieve tension is produced with a left-hand and right-hand thread. The bearings are easily accessible and can be quickly lubricated.

## Versions.

- For cold handling
- For nitrogen handling

## Technical data.

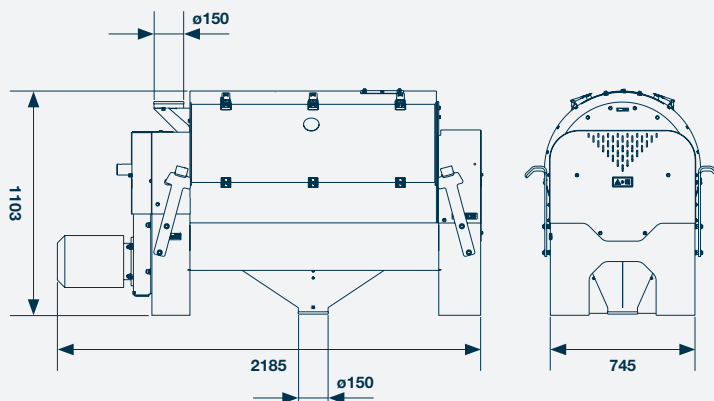

		<b>MKZH</b>
<b>Hop powder throughput</b>	t/h	approx. 0.5
<b>Weight (net)</b>	kg	720
<b>Motor power</b>	kW	4
<b>Min. temperature range</b>	°C	-40
<b>Inlet diameter</b>	mm	200
<b>Outlet diameter</b>	mm	200