

Bag Belt Conveyor.

MWTK

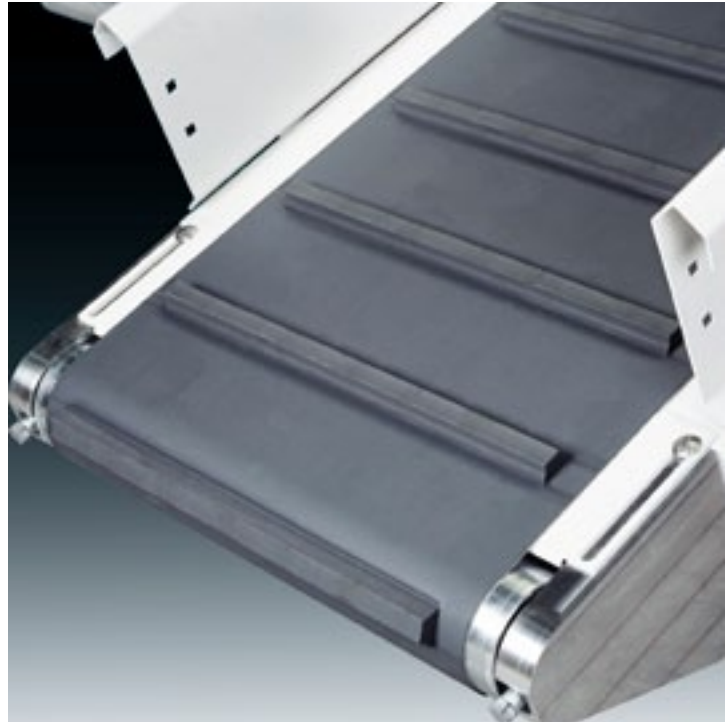

Reliable and gentle handling. Sliding belt design.



MWTB bag belt conveyor – for inclined conveying up slopes of up to 25°.

Wide variety of applications

MWTB belt conveyors are designed to ensure reliable, gentle handling of paper, textile, and plastic bags and other containers with weights up to 100 kg. For container sizes up to 600 mm width, conveyor belts with widths of 500 and 600 mm are used. Depending on the particular type of container, inclined conveying up slopes up to 25 degrees is possible.

Design

MWTB belt conveyors are so-called sliding belt designs. The belts slide over a table along the conveying section. This design allows containers to be loaded onto the conveyor at any point along the conveying section. For lateral container discharge, it is advantageous to apply a deflection belt.

Supports, guide boards

The supports are an appropriate solution to support or suspend the belt conveyor. The guide boards prevent the bags or containers conveyed from breaking away sideways. The guide boards are made of steel and can be adjusted on site.

Features

- Rugged design with direct drive
- Perfect guidance of the material conveyed
- Reliable operation, gentle conveying
- Conveying up slopes of up to 25 degrees

Numerous possible combinations. Modular system.

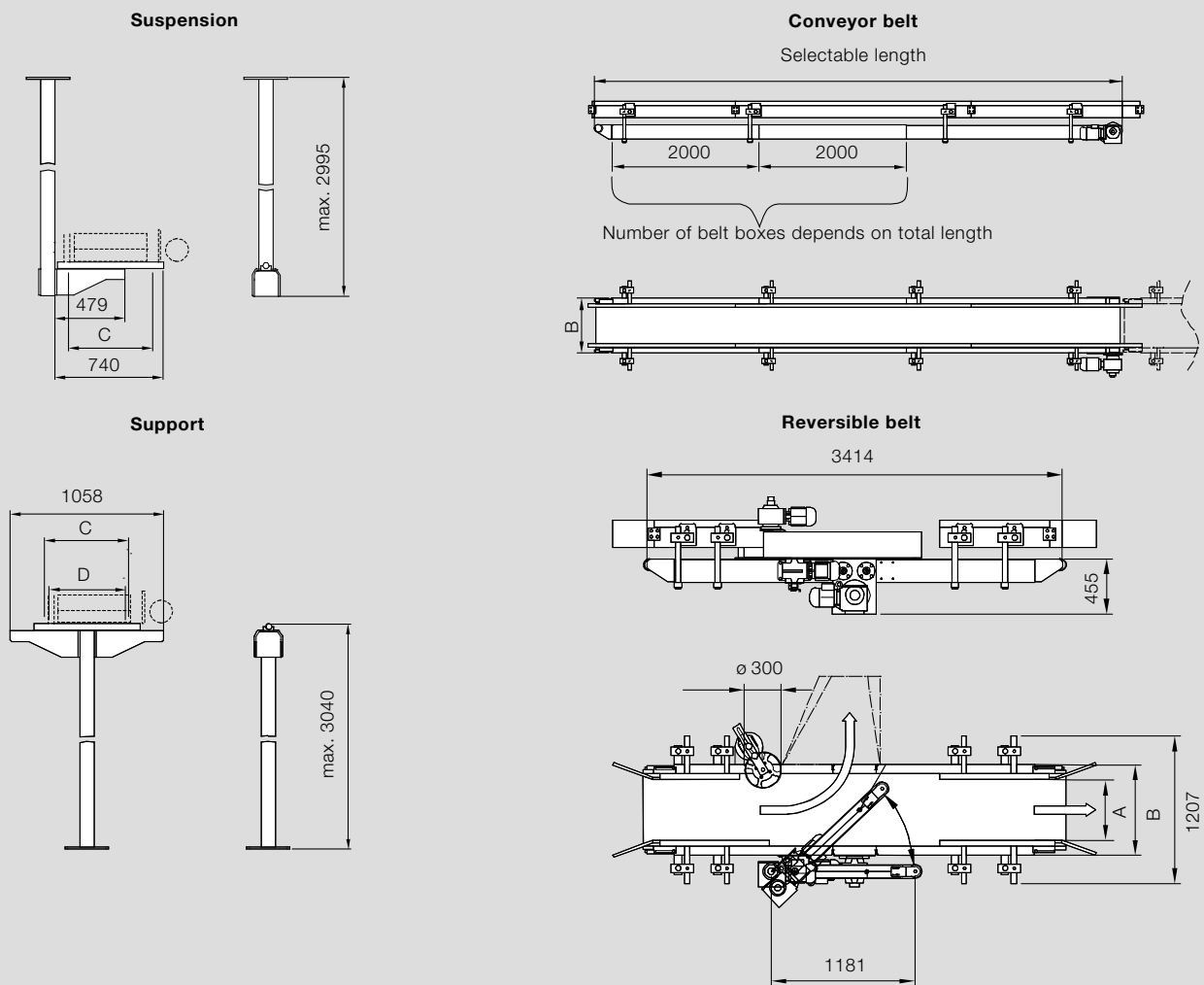

Technical data, dimensions (mm)

Speed	Conveyor belt 500/600					
	0.4		0.6		0.8	
Inclination	0° - 15°	> 15° - 25°	0° - 15°	> 15° - 25°	0° - 15°	> 15° - 25°
Selectable length	1217 - 19,117*	1217 - 15,117*	1217 - 15,117*	1217 - 11,117*	1217 - 11,117*	1217 - 5117*
A	500/600		500/600		500/600	
B	641/741		641/741		641/741	
C	581/681		581/681		581/681	
D	529/629		529/629		529/629	
E	581/681		581/681		581/681	

* Lengths can only be selected in increments of 100 mm

Bühler AG
CH-9240 Uzwil, Switzerland
T +41 71 955 11 11
F +41 71 955 66 11
www.buhlergroup.com

